

Student Comments about WEST Training

The best gauge of the effectiveness of any course is the feedback from attendees. Here are some comments from students about WEST courses and seminars.

“All the instructors did an exceptional job presenting the material. I gained a vast amount of knowledge with this course and I look forward to returning to the field to use it”
Super Major Operator, May 2011

“All instructors are very good and knowledgeable”
Drilling Contractor, April 2011

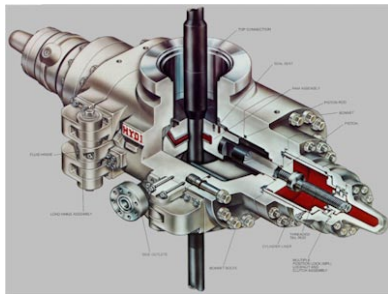
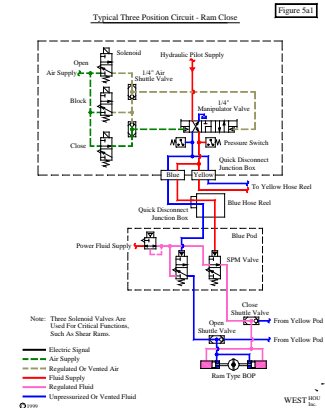

“Excellent course”
Drilling Contractor, Feb 2011

“Thank you for an informative and great week. It was very beneficial to me and I look forward to attending future courses at WEST. I will definitely recommend to others within our organization.”
Major Operator, February 2011

“Enjoyed the seminar very much. Will recommend to all my co-workers!”
Operator, February 2011

“The entire school was full of valuable information for me, the in-depth explanation of equipment usage and troubleshooting problems was excellent.”
Major Operator, January 2011

“Course is excellent and very informative and therefore nothing I would change.”
Drilling Contractor, November 2010



Control panel for subsea control unit

“Everything in the course was useful.”
 Drilling Contractor, November 2010

“Excellent course!”
 Regulatory agency, Sep 2010

“This was the best training I've been through [instructor] was a great instructor and a pleasure to be around.”
 Regulatory agency, Sep 2010

“Hard to improve on. It was by far the most hospitable course I've been to in 9 years in the oilfield and that includes the owner, Michael Montgomery.”
 Drilling Contractor, April 2010

“Excellent level of everything. The technical depth was long enough but enough to leave us wanting more. The hospitality, service and food was outstanding. Definitely the best of any course I have been to.”
 Major operator, April 2010

“This is the most beneficial course I have ever attended. I am leaving with a better understanding in many areas. ... money well spent. Looking forward to other courses. (instructor) did a fine job in every aspect, second to none! Thanks!”
 Drilling Contractor, March 2010



Students troubleshooting subsea control pods during the Subsea Controls course



Students applying course material “hands-on”

“...Another great course - congrats on the new facility - very nice. I will be back again.”
 Major operator, January 2010

“This is one of the best, most useful schools that I have attended.”
 Drilling Contractor, November 2009

“I thought he [the instructor] communicated the info. into terms that everyone in the class could understand. He stuck with people till the light came on and they understood.”
 Drilling Contractor, November 2009

“Actual problems and issues. The expertise of instructors is invaluable and unprecedented compared to other courses similar to this.”

Major operator, November 2009

“The instructors are very good at teaching the course in a way so you can understand it. Everyone at the course from the instructors to the personnel that worked in the offices were great! Their hospitality was the best I have ever seen from any class I have been to before. So, thanks to all for making this class a good one while I was here.”

Major operator, May 2009

“Excellent course and facilities with friendly and helpful staff. Looking forward to next course!”

Large drilling contractor, April 2009

“The hospitality of the company was over the top!.....I will for sure want to come back at another time.”

Drilling equipment services, February 2009



Students getting familiar with some accumulator bottles and a bladder